

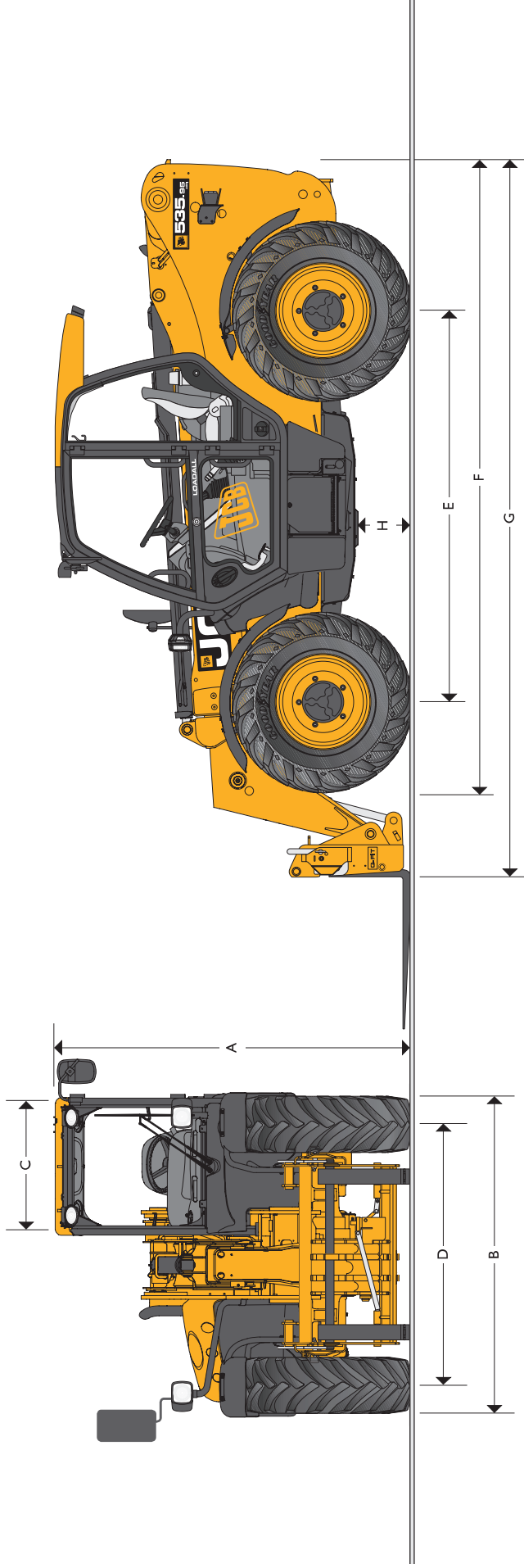

MAX. PAYLOAD: 3500kg (771 lb) MAX. LIFT HEIGHT: 9.5m (31ft 2in)



STATIC DIMENSIONS

Machine model	535-95	Machine model	535-95
A Overall height	2.49 (8-2) m (ft-in)	H Ground clearance	0.40 (1-4) m (ft-in)
B Overall width (over tyres)*	2.36 (7-9)	Outside turn radius (over tyres)	3.7 (12-2)
C Inside width of cab	0.94 (3-1)	Carriage roll back angle	41.0 degrees
D Front track	1.87 (6-1)	Carriage dump angle	24.0 degrees
E Wheelbase	2.75 (9-0)	Weight – Fixed	8020 (17681) kg (lb)
F Overall length to front tyres	4.38 (14-4)	Tyres	445/70 R24
G Overall length to front carriage	4.99 (16-4)		

Note: Machine shown with optional roof mounted air conditioning fitted on Agri Plus and Agri Super.
*Dependant upon tyre specified.

LIFT PERFORMANCE

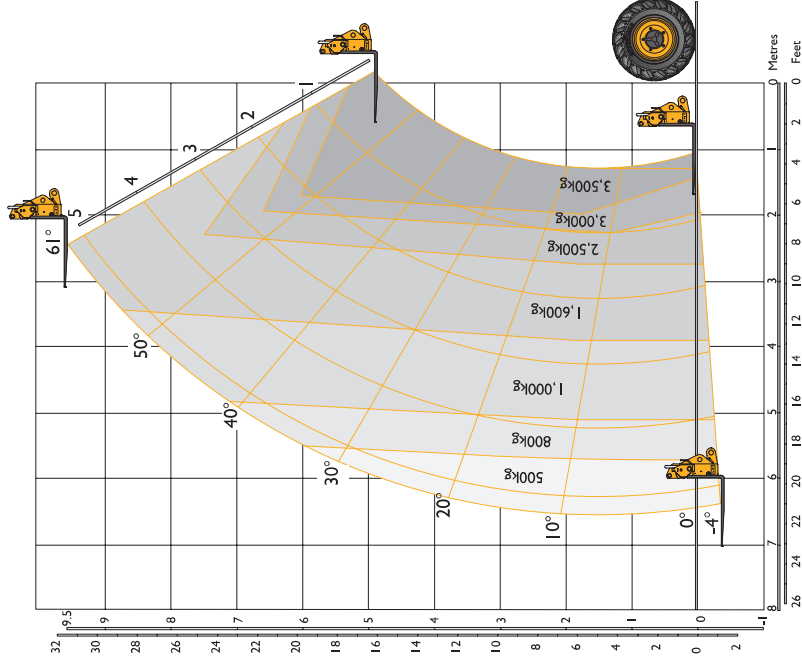

LIFT PERFORMANCE

Machine Model	535-95
Maximum lift capacity	3500 (7716) kg (lb)
Lift capacity to full height	1600 (3527) kg (lb)
Lift capacity at full reach	500 (1102) kg (lb)
Lift height	9.50 (31-2) m (ft-in)
Reach at maximum lift height	2.43 (7-11) m (ft-in)
Maximum forward reach	6.52 (21-5) m (ft-in)
Reach with 1 tonne load	5.08 (16-8) m (ft-in)
Placing height	8.78 (28-9) m (ft-in)

Complies with stability test EN 1459 Annex B.

ENGINE

Latest technology and advanced design provides low fuel consumption, reduced noise, high torque and power output, total reliability and minimal maintenance. Two-stage, dry type air filter with primary and safety elements. Territory dependent.

Model	Stage II Agri	Stage III Agri	Stage III Agri Plus/ Super	Stage IIIb Agri	Stage IIIb Agri Plus/ Super
Manufacturer	JCB	JCB	JCB	JCB	JCB
Displacement	4.4 (269) ltr (in ³)	4.4 (269)	4.4 (269)	4.4 (269)	4.4 (269)/ 4.8 (293)
No. of cylinders	4	4	4	4	4
Bore size	mm (in)	103 (4.05)	103 (4.05)	103 (4.05)	103 (4.05)/ 106 (4.17)
Stroke	mm (in)	132 (5)	132 (5)	132 (5)	132 (5)/135 (5)
Aspiration	Turbo	Turbocharged cooled	Turbocharged cooled	Turbocharged cooled	Turbocharged cooled
Power rating					
Power @ 2200rpm	kW (HP)	74.2 (100)	74.2 (100)	97 (130)	93 (125)/ 108 (145)
Torque rating					
Torque @ 1300rpm	Nm (lbf ft)	425 (313)	440 (324)	—	—
Torque @ 1500rpm	Nm (lbf ft)	—	—	532 (392)	550 (406)/ 560 (413)

TRANSMISSION

Stage II / III

Agri / Agri Plus: JCB powershift transmission incorporating torque converter, bevel box and 4 speed powershift gearbox in one resiliently mounted unit. A combined steering column mounted switch incorporating directional control and 4 forward and 4 reverse powershift gears. Travel speed 33kph (20mph). Permanent 4 wheel drive.

Agri Super: JCB 6 speed transmission incorporating torque converter, bevel box and 6 speed powershift gearbox with TorqueLock in 5th and 6th gear in one resiliently mounted unit. 3 operating modes: Eco, Power and Field. Travel speed 40kph (25mph). Transmission kick down. Electrical 2/4 wheel drive select.

A combined steering column mounted switch incorporating directional control and 6 forward and 4 reverse powershift gears with auto-selection between 4th and 6th gear in Eco and 3rd – 6th gear in Power mode.

Stage IIIb

Agri / Agri Plus: JCB powershift transmission incorporating torque converter, bevel box and a 4 speed powershift gearbox in one resiliently mounted unit. Manual gear shift incorporated onto the single lever joystick with 4 forward and 4 reverse powershift gears. Travel speed 33kph (20mph). Permanent 4 wheel drive. Switchable transmission disconnect on brake pedal.

Agri Super: JCB 6 speed transmission incorporating torque converter, bevel box and 6 speed powershift gearbox with TorqueLock in 5th and 6th gear in one resiliently mounted unit. 2 operating modes: Manual and Auto. Travel speed 40kph (25mph). Electrical 2/4 wheel drive select. Gear shift on single lever joystick. Auto selection between 4th and 6th gear in auto mode. Switchable transmission disconnect on brake pedal.

Front and rear drive axles: JCB epicyclic hub reduction drive/steer axes with Max-Trac torque proportioning differentials.

BRAKES

Service brakes: Servo-assisted hydraulically activated, self-adjusting, oil-immersed in-board high back-off multi-disc type on front axle.

Parking brake: Hand operated disc brake on output of gearbox (93kW/125hp, 97kW/130hp, 108kW/145hp – oil immersed disc type).

BOOM AND CARRIAGE

Boom is manufactured from high tensile steel.
 Low maintenance, hard wearing pads.
 JCB Q-fit self-levelling carriage with lever operated pin locking accepts pallet forks and a wide range of attachments.
 One boom end auxiliary hydraulic service fitted as standard.

SAFETY CHECK VALVES

Fitted to carriage tilt, telescopic and boom lift rams.

SERVICE CAPACITIES

Fuel tank	litres (UK gal)	146 (32.1)
Hydraulic tank	litres (UK gal)	113 (24.8)
Coolant	litres (UK gal)	23 (5.1)

HYDRAULICS

Operating system pressure	bar (PSI)	Agri (3500)	AgriPlus/Agri Super (3500)
Main hydraulics	litres/min	140	140
Pump		Variable	Variable
Loader controls		Cab mounted single lever joystick – Electric servo control of lift & lower/crowd & dump - Proportional extend/retract/aux	Cab mounted single lever joystick – Electric servo control of lift & lower/crowd & dump - Proportional extend/retract/aux
Hydraulic cycle times		seconds	seconds
Lift		6	5.9
Lower		5.2	4.9
Extend		12.3	10.0
Retract		11.4	9.5
Bucket dump		2.0	2.0
Bucket crowd		2.4	2.3

ELECTRICS

12 v negative earth, 95 AH battery, 95 amp alternator, Full road lighting, Reversing light, Direction indicators, Hazard warning, Reverse alarm.

DELUXE CAB

Quiet, safe and comfortable cab conforms to ROPS ISO 3471 and FOPS ISO 3449, Tinted glass all round with laminated front and roof screen, Roof bars, front, rear and roof screen wash/wipe and heater/screen demister, Opening rear window, Audio-visual warning system for coolant temperature, water in fuel, engine oil pressure, air cleaner, battery charge, transmission oil temperature and pressure, Hourmeter and road speed indicator, engine temperature, fuel gauge and clock, Adjustable steer column with stalk bar, powershift change and forward reverse shuttle, Throttle and brake pedal floor mounted, Adjustable deluxe suspension seat with adjacent park brake.

Automatic eye level audio-visual load moment indicator warning system receiving a signal from a load sensor on the rear axle, This system continuously monitors the machine's forward stability and leaves the operator in control at all times, Operator presence switch in seat (Stage IIb machines), *Adaptive Load Control for EU territories conforms to EN15000.

Hydraulic controls:

Agri/Plus/Super: Cab mounted single lever servo joystick, incorporating forward/neutral/reverse, with progressive extend/retract and auxiliary incorporating constant flow facility.

STEERING

Hydrostatic power steering with power track rods on both axles, Three steer mode options: front wheel steer, all wheel steer, crab steer: operated from in the cab by a selection switch, with automatic alignment.

OPTIONS AND ACCESSORIES

Options: Front and rear working lights, rotating flashing beacon, fire extinguisher, radial industrial tyres, electrical 2/4WD select, limited slip differential in front axle, windscreens and roof guard, air suspension seat, roof and front screen blind, radio kit, air conditioning, reversing fan, 2 speed and intermittent front wash/wipe, smoothride system, towing facility with trailer lighting package, carriage options available – contact your local dealer.

Attachments: Contact your local dealer for details of the comprehensive range.



A GLOBAL COMMITMENT TO QUALITY

JCB's total commitment to its products and customers has helped it grow from a one-man business into Britain's largest privately owned manufacturer of backhoe loaders, crawler excavators, wheeled excavators, telescopic handlers, wheeled loaders, dump trucks, rough terrain fork lifts, industrial fork lifts, mini/midi excavators, skid steer loaders, tractors and compaction equipment.

By making constant and massive investments in the latest production technology, the JCB factories have become some of the most advanced in the world.

By leading the field in innovative research and design, extensive testing and stringent quality control, JCB machines have become renowned all over the world for performance, value and reliability.

And with a global sales and service network of more than 650 dealers and agents, we aim to deliver the best customer support in the industry.

Through setting the standards by which others are judged, JCB has become one of the world's most impressive success stories.

